

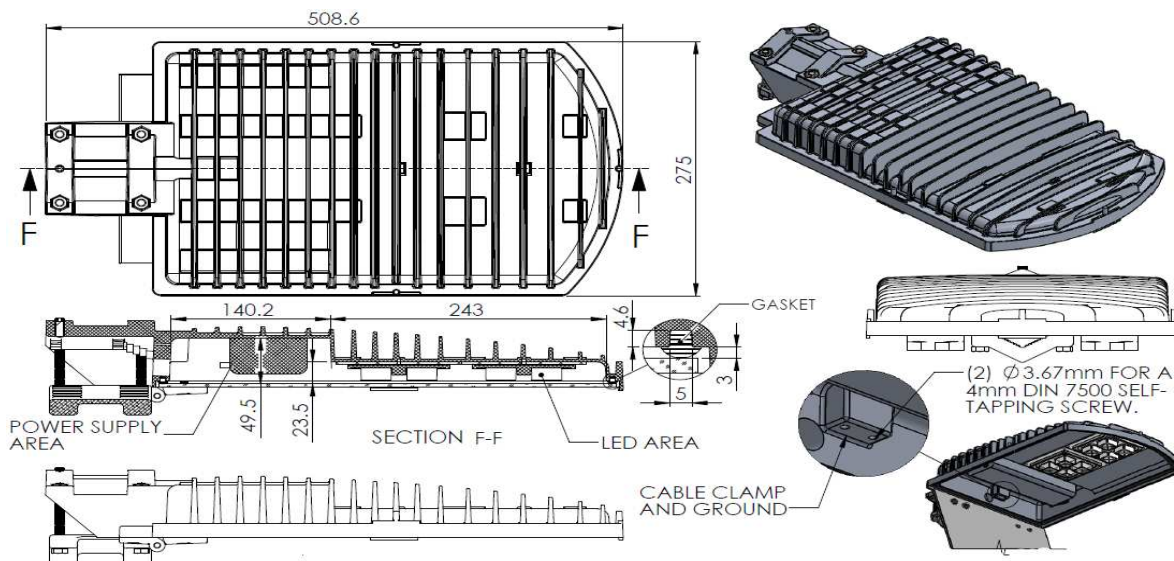

Apollo SL5 mini – The ideal LED lamp for outdoor use that is highly cost-effective. The robust die cast aluminum housing with its finned surface guarantees excellent heat management. The light is ETL listed and conforms to UL STD 1598.

- for street, roadway and parking lot lighting applications
- heat management system assures long LED life and minimal lumen depreciation
- tool-less entry for ease of maintenance
- modular LED design with the ability to easily replace LEDs in the field
- universal mounting design
- best lumens per watt/lumen per dollar in the industry
- mil-spec components to withstand the hottest and coldest climates
- wireless control on UHF and 900 MHz
- adjustable elevation in mounting bracket

Number of LEDs	8
Lumen@4000k	17900
Typical Power Consumption (W)	150



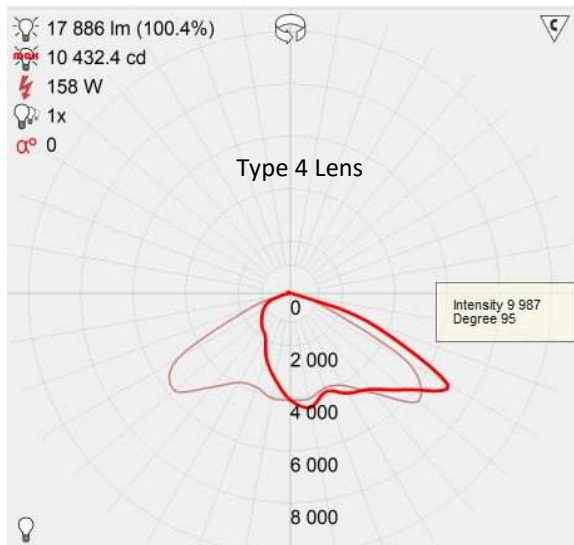
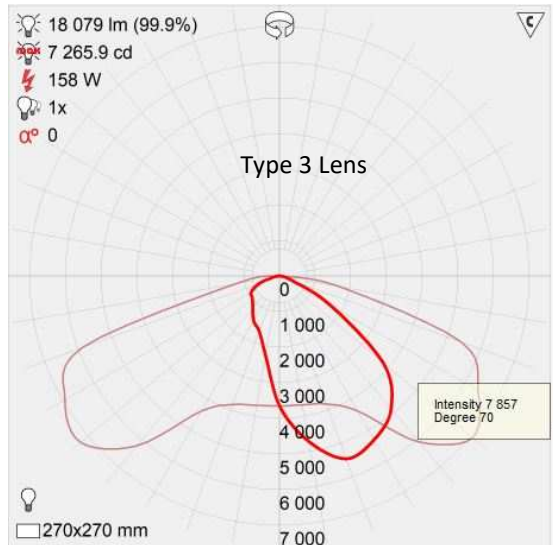

Electrical	
Input Voltage	100-277 V AC or 480 V AC or 48 V DC
Frequency Range	50/60 Hz
Surge Spike Protection	Compliance to EN61000-4-5 6 kV, 10 kV line to ground
Optical	
Light Source	CREE XHP 70-2
Color Temperature	4000 K – others on request
Custom Design Lens Source	LEDIL
Beam Pattern	Type III or type IV, others on request
Environmental	
Operating Temperature	-40 to +85C
Mechanical	
Dimensions	520 x 280 x 75 mm
Weight	12.8 Lbs. (5.8kg)
Material	Aluminum Alloy / Glass
Wind Load	0.0336 m ² = 0.362 sqft
Mounting	2.6"/63 mm